

California Civil Seismic Principles

Practice test

April 6, 2026

Time limit: 150 minutes

Official exam page

californiacerts.com/exams/ca-civil-seismic

Online timed practice

californiacerts.com/exams/ca-civil-seismic/practice

If the link does not open, copy and paste the full URL into your browser.

Answer key for this session (PDF):

californiacerts.com/resources/pdfs/ca-civil-seismic/ca-civil-seismic-practice-solution.pdf

1. When analyzing a structure with a "Rigid Diaphragm", how is the lateral force distributed to the vertical resisting elements?

- A. Equally to all vertical elements
- B. Based on the tributary area of each element
- C. Based on relative stiffness of vertical elements
- D. Based on the height of each element

2. Which ASCE 7-16 parameter accounts for the importance of a facility to the community (e.g., a hospital vs. a storage shed) when determining the design seismic base shear?

- A. The Overstrength Factor (Ω_0)
- B. The Redundancy Factor (ρ)
- C. The Deflection Amplification Factor (C_d)
- D. The Seismic Importance Factor (I_e)

3. In Modal Response Spectrum Analysis, the base shear (V) must be scaled if it is less than what percentage of the base shear (V) calculated using the ELF procedure?

- A. 85%
- B. 75%
- C. 50%
- D. 100%

4. For the Equivalent Lateral Force procedure, the fundamental period T shall NOT exceed the product of the coefficient C_u and the approximate period T_a . What is the purpose of this $C_u * T_a$ limit?

- A. Decreases the base shear for tall buildings
- B. Limits the weight of the structure
- C. Prevents an unsafely low design base shear
- D. Allows for a more flexible design

5. According to ASCE 7-16 Section 12.8.3 and the provided vertical distribution diagram, for a structure with a fundamental period $T \leq 0.5$ seconds, what is the value of the exponent k used to calculate the vertical distribution factor C_{vx} ?

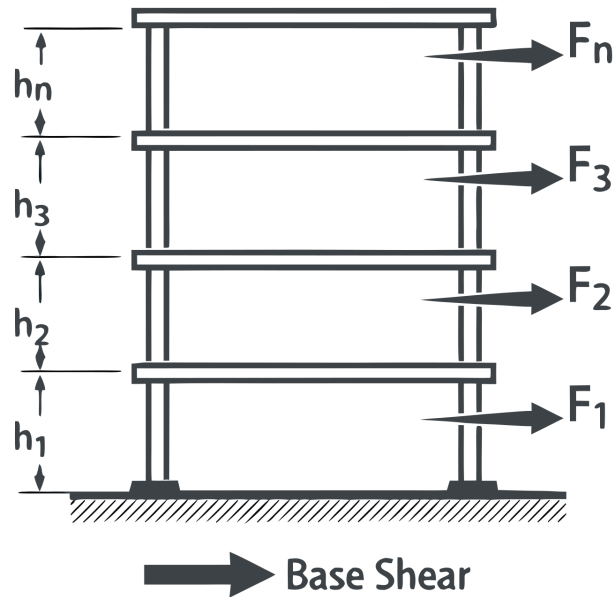

- A. $k = T$
- B. $k = 2.0$
- C. $k = 0.5$
- D. $k = 1.0$

6. For the design of architectural components (e.g., heavy suspended ceilings), the seismic design force F_p is calculated as a function of the component's weight (W_p) and what other critical factor at the point of attachment?

- A. The total square footage of the component
- B. The distance to the nearest active fault
- C. The height of the attachment relative to the building height (z/h)
- D. The structural material of the primary frame (steel vs concrete)

7. In the vertical distribution of forces, what does the variable " w_x " represent?

- A. Portion of total effective seismic weight at level x
- B. Wind pressure at level x
- C. Live load at level x
- D. Total height of the level x

8. True or False: All welding of seismic force-resisting elements must be performed by certified welders and is subject to special inspection.

- A. Only required for full-penetration welds
- B. False
- C. Only applies to SDC F
- D. True

9. When using the ELF procedure, the seismic response coefficient C_s is a function of the Response Modification Coefficient (R). What does R represent?

- A. Soil site class factor
- B. The stiffness of the foundation
- C. Building height multiplier
- D. Ductility and overstrength of the system

10. When a structure has a Re-entrant Corner irregularity, ASCE 7-16 Section 12.3.3.4 requires that the design forces be increased by what percentage for the design of the connection between the diaphragm and the vertical elements?

- A. 10%
- B. 50%
- C. 25%
- D. 100%

11. True or False: Orthogonal effects (loading in two perpendicular directions simultaneously) must be considered for all structures in SDC C.

- A. False
- B. True
- C. Only for essential facilities
- D. Only for wood structures

12. Based on ASCE 7-16 Table 12.3-1 and the provided plan view, at what projection percentage (A/L) is a Re-entrant Corner Irregularity (Type 2) classified as existing in the structure?

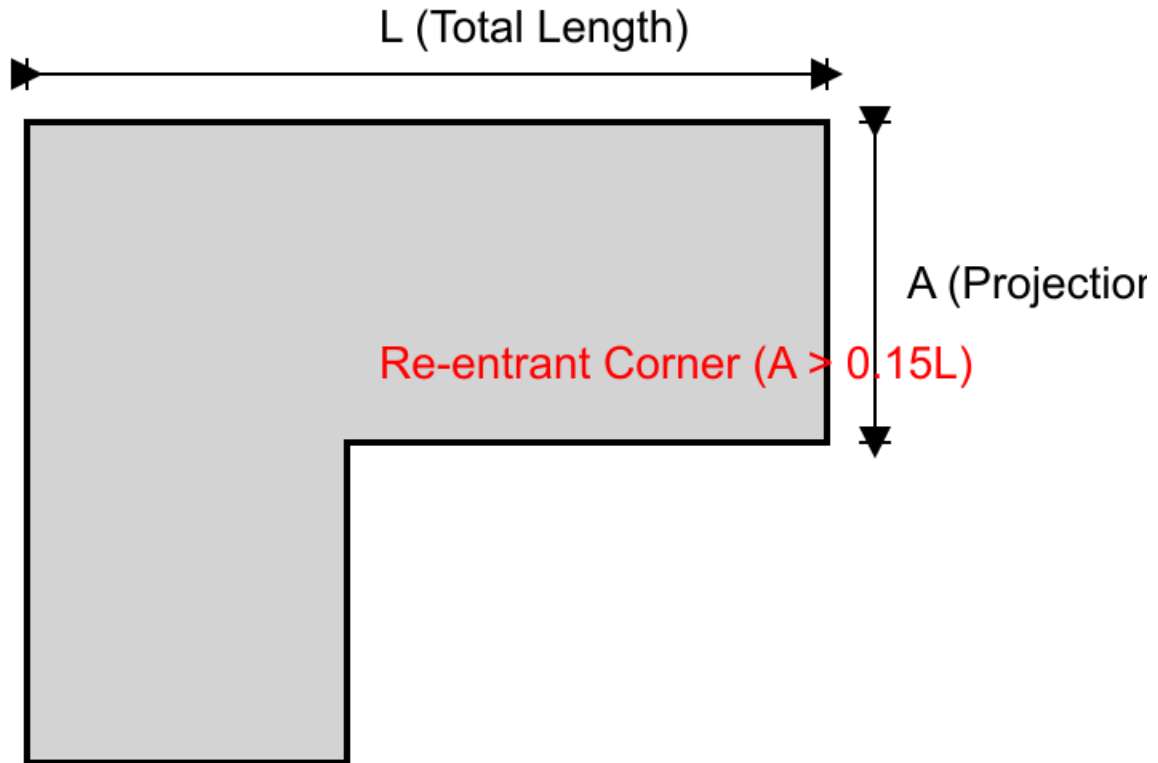

- A. 15%
- B. 10%
- C. 20%
- D. 25%

13. Which Risk Category is assigned to "essential facilities" such as hospitals, fire stations, and police stations?

- A. Risk Category IV
- B. Risk Category III
- C. Risk Category II
- D. Risk Category I

14. Based on ASCE 7-16 Table 11.6-1 and the provided flowchart, what is the Seismic Design Category (SDC) for a Risk Category II structure where the short period design spectral response acceleration (S_{ds}) is determined to be $0.55g$?

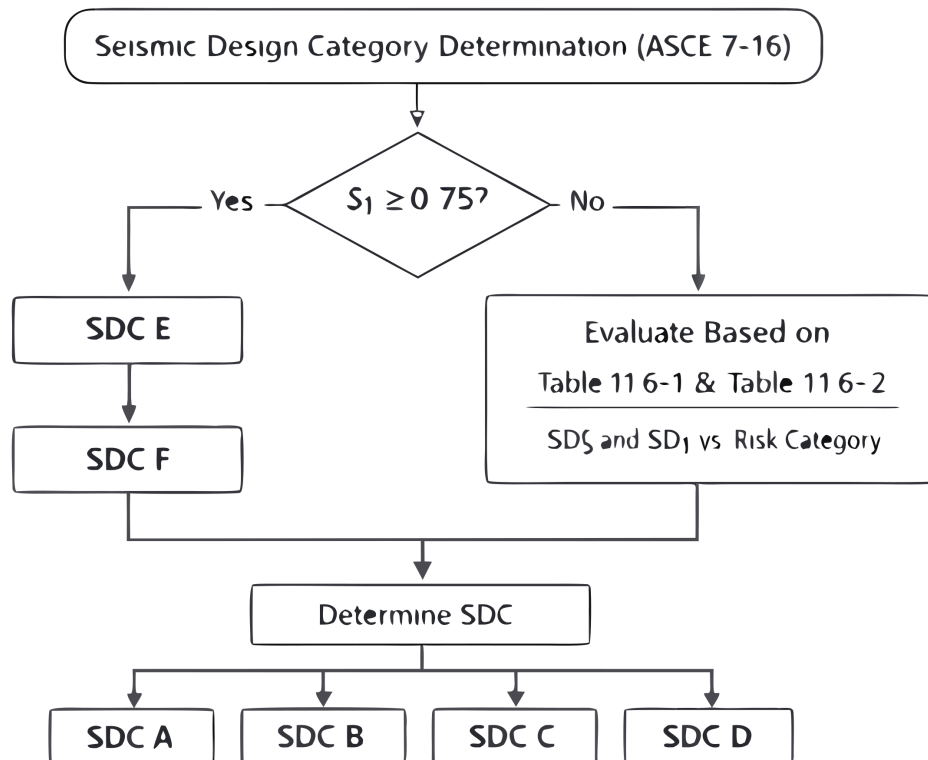

- A. SDC B
- B. SDC C
- C. SDC D
- D. SDC A

15. True or False: According to ASCE 7-16, the base shear V must be distributed vertically using a linear triangular distribution ($k=1$) for all buildings, regardless of height.

- A. Only for Risk Category IV buildings
- B. False
- C. Only for SDC A buildings
- D. True

16. Per ASCE 7-16 Section 12.8.1.1, the seismic response coefficient C_s shall NOT be less than which of the following?

- A. $0.01 * SD1 * I_e$
- B. $SDS / (R/I_e)$
- C. $0.2 * SDS$
- D. $0.044 * SDS * I_e$

17. The diagram represents a Single Degree of Freedom (SDOF) dynamic system. In seismic engineering, the fundamental natural period (T) of this simple system is calculated as a function of its Mass (M) and which other labeled property?

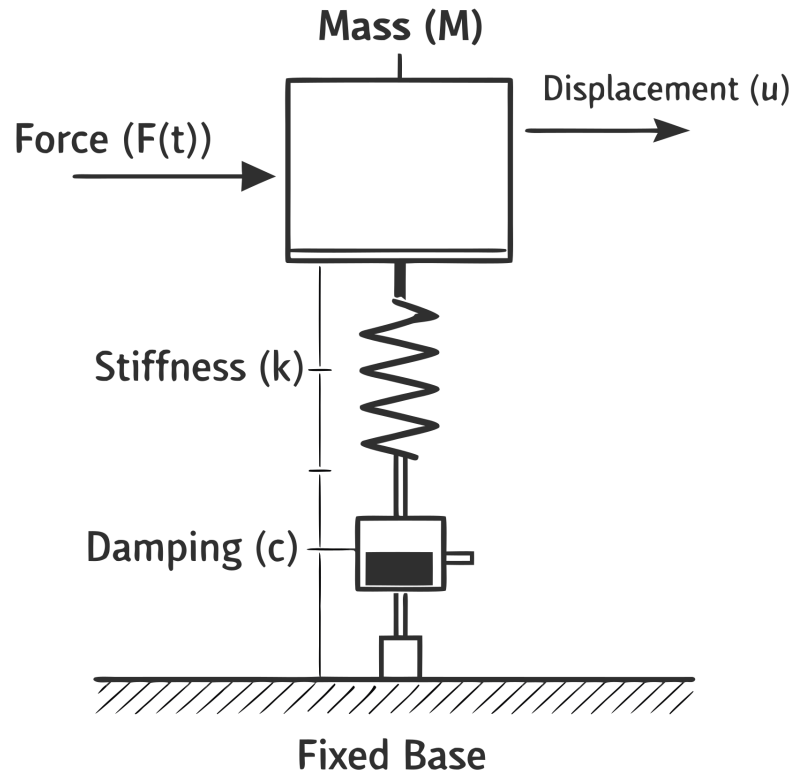

- A. Damping (c)
- B. Stiffness (k)
- C. Force (F)
- D. Velocity (v)

18. What is the "Overstrength Factor" (Ω_0) used for in seismic design?

- A. Decrease the spectral acceleration
- B. Increase the design base shear for the entire building
- C. Account for live load reductions
- D. Design critical elements for the maximum deliverable force

19. According to ASCE 7-16, a Soft Story Irregularity (Type 1a) is defined to exist where the lateral stiffness of a story is less than what percentage of the stiffness of the story above?

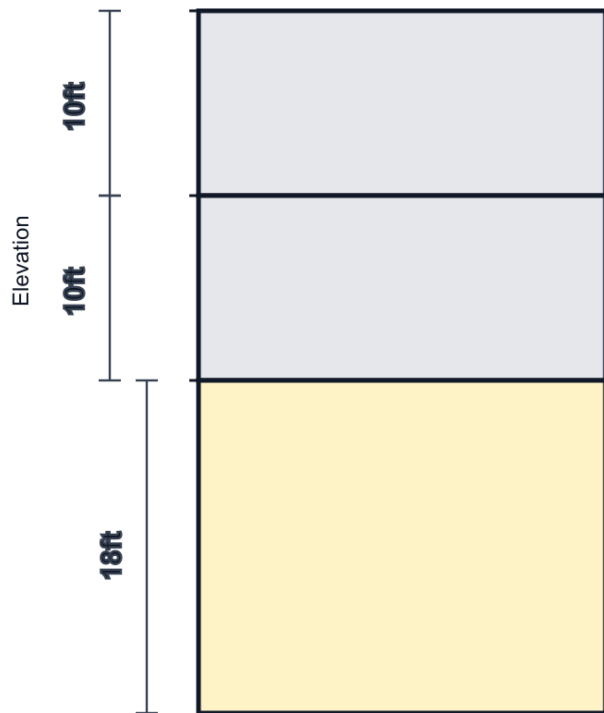

Elevation (story heights shown — Type 1a soft story relates lateral stiffness between adjacent levels)

- A. 80%
- B. 90%
- C. 50%
- D. 70%

20. The provided cross-section shows a Special Boundary Element at the edge of a concrete shear wall. What is the primary structural purpose of the closely spaced transverse confinement hoops shown in this boundary element?

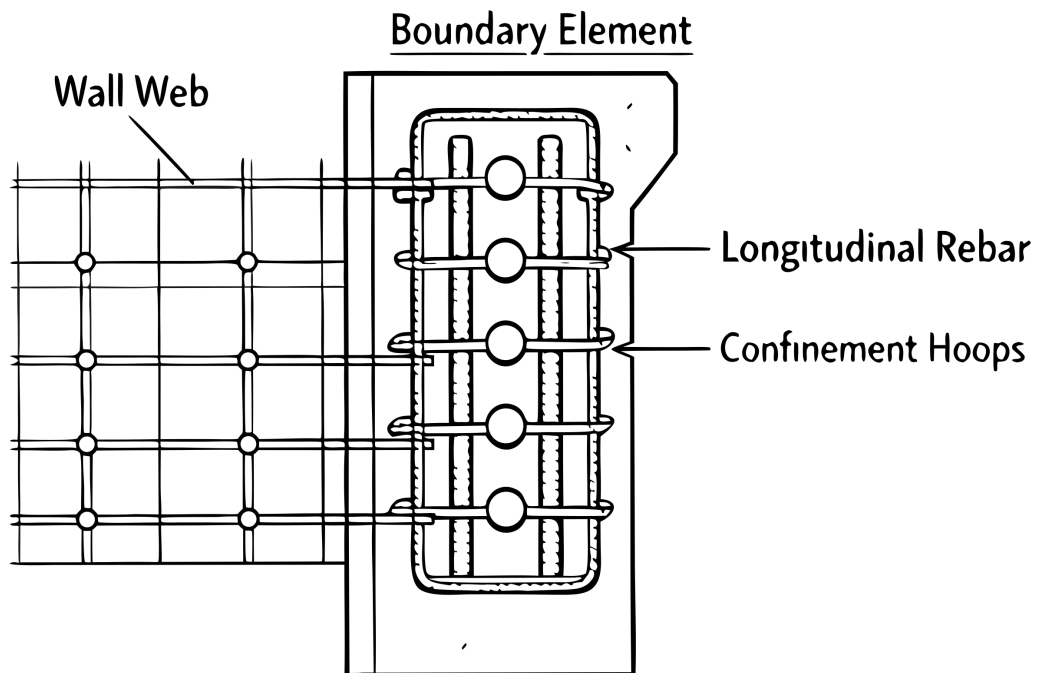

- A. To increase the pure flexural tensile strength of the wall
- B. To provide confinement for the concrete and prevent buckling of longitudinal reinforcement
- C. To reduce the overall weight of the boundary element
- D. To serve as the primary shear transfer mechanism across horizontal construction joints

21. A "Flexible Diaphragm" is typically defined as a diaphragm made of which material?

- A. Concrete slab
- B. Composite deck
- C. Wood-sheathed or unfilled metal deck
- D. Steel plate

22. Based on the provided drift diagram, the interstory drift (Delta) is calculated as the difference between the deflections at the top and bottom of the story under consideration. According to ASCE 7-16, for most Risk Category II structures, what is the typical allowable story drift limit (Delta_a) for a story height h_{sx}?

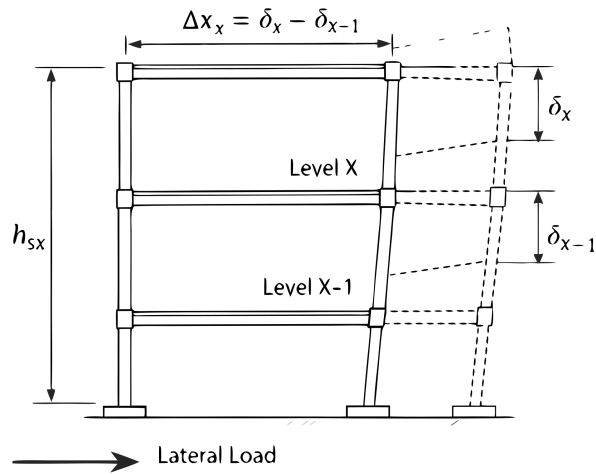

- A. $0.010 * h_{sx}$
- B. $0.025 * h_{sx}$
- C. $0.020 * h_{sx}$
- D. $0.015 * h_{sx}$

23. According to ASCE 7-16 Section 11.4.6 and the provided diagram, for a period T such that $T_0 \leq T \leq T_s$, what is the design spectral response acceleration S_a ?

ASCE 7-16 Horizontal Design Response Spectrum

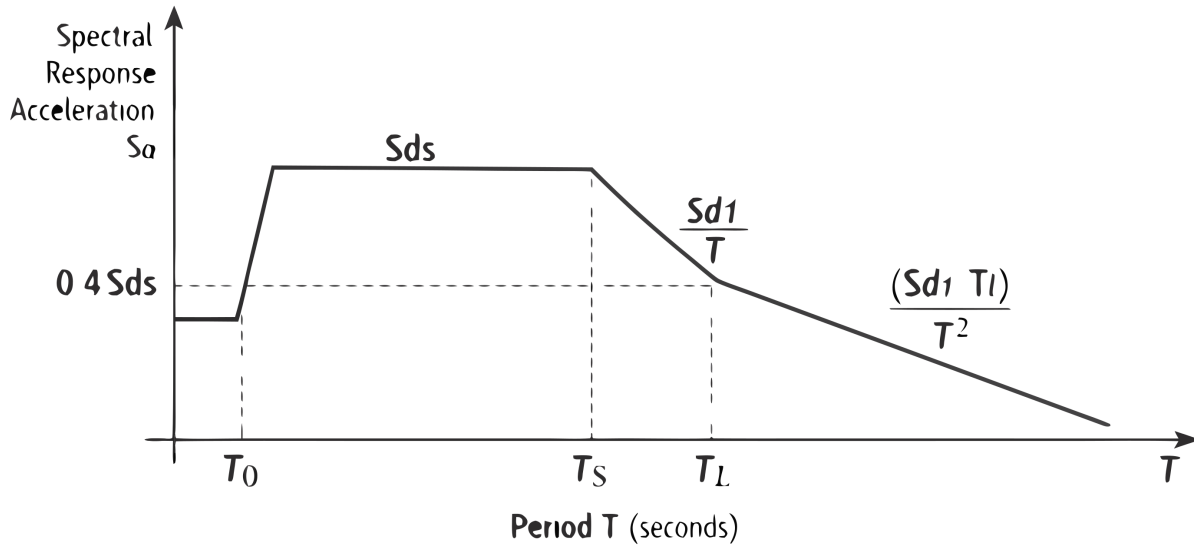

- A. $(S_{d1} * T_L) / T^2$
- B. S_{d1} / T
- C. $S_{ds} [0.4 + 0.6 (T / T_0)]$
- D. S_{ds}

24. The provided detail drawing shows a lap splice for longitudinal column rebar in a concrete Special Moment Frame. According to ACI 318 (referenced by ASCE 7), lap splices in special moment frame columns must be enclosed within what type of reinforcement?

Class B Lap Splice of Longitudinal Rebar

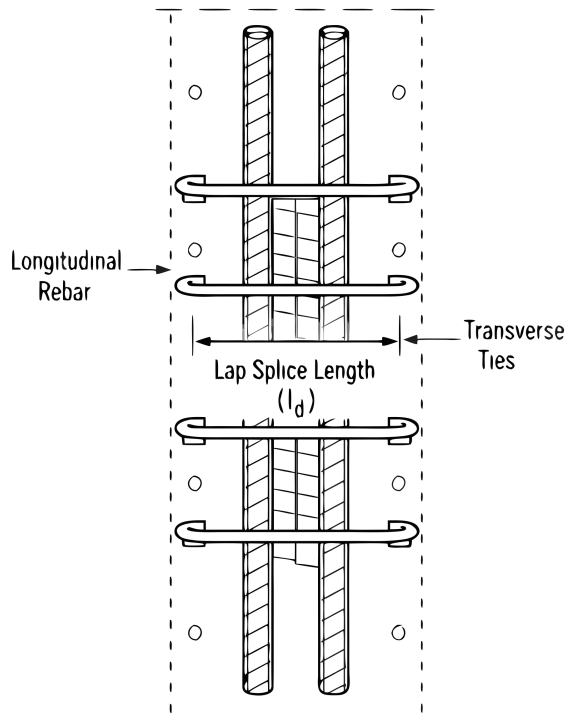

- A. Closely spaced transverse ties or hoops
- B. Additional longitudinal rebars clustered together
- C. Heavy gauge welded wire mesh
- D. A solid steel jacket casing

25. The provided diagram illustrates the P-Delta effect. According to ASCE 7-16 Section 12.8.7, P-Delta effects on story shears and moments do NOT need to be considered when the stability coefficient (theta) is equal to or less than:

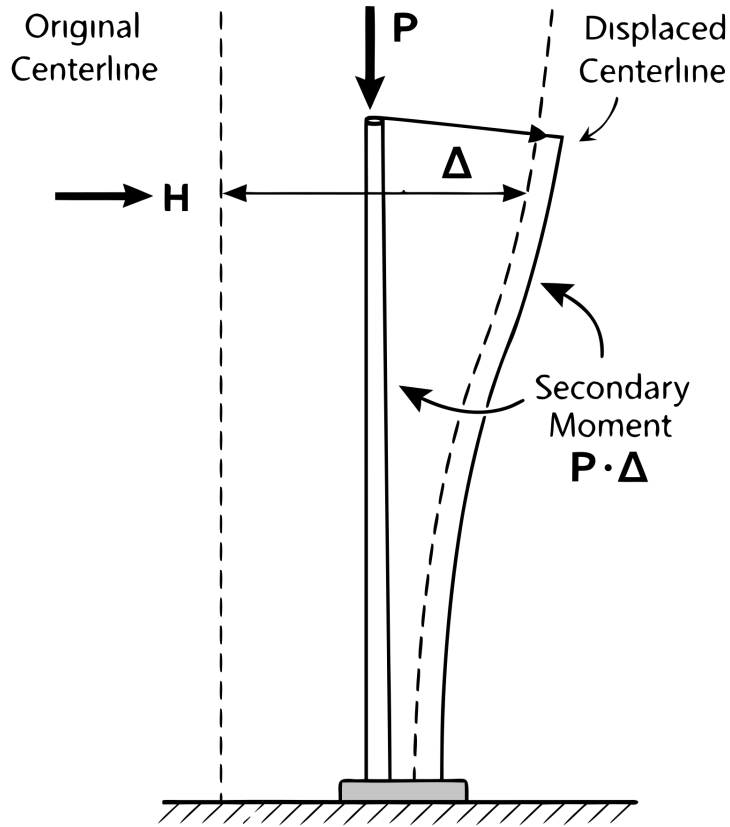

- A. 0.05
- B. 0.25
- C. 0.15
- D. 0.10

26. According to ASCE 7-16 Table 12.3-2, a Vertical Geometric Irregularity (Type 4) exists when the horizontal dimension of the seismic force-resisting system in any story is more than what percentage of that in an adjacent story?

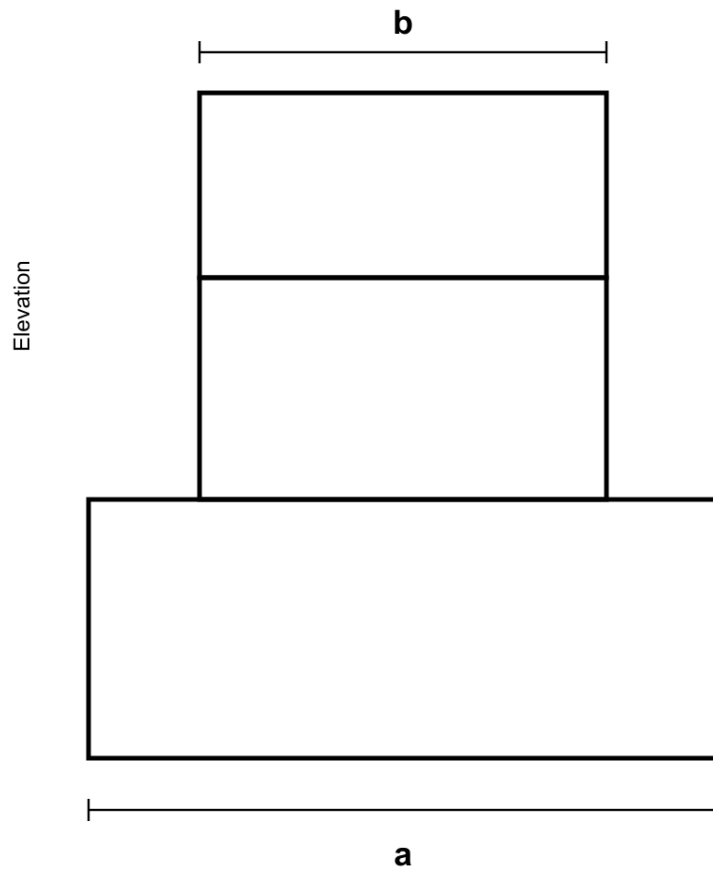

$a > 130\%$ of b (adjacent horizontal dimensions)

- A. 110%
- B. 125%
- C. 150%
- D. 130%

27. The design spectral response acceleration parameter for short periods (SDS) is defined as what fraction of the MCER parameter SMS?

- A. 1.0
- B. 2/3
- C. 1/2
- D. 3/4

28. On the design response spectrum, the period T_s is defined by the ratio of which two parameters?

- A. $SDS / SD1$
- B. $0.2 * SD1 / SDS$
- C. $SD1 / T$
- D. $SD1 / SDS$

29. The elevation diagram shows a shear wall terminating at the second floor, with forces transferring into columns below. According to ASCE 7-16 Table 12.3-2, this is classified as an In-Plane Discontinuity in Vertical Lateral Force-Resisting Element (Type 4) irregularity. Under what condition is this irregularity considered to exist?

In-Plane Discontinuity in Vertical Lateral Force-Resisting Element (Type 4 Vertical Irregularity)

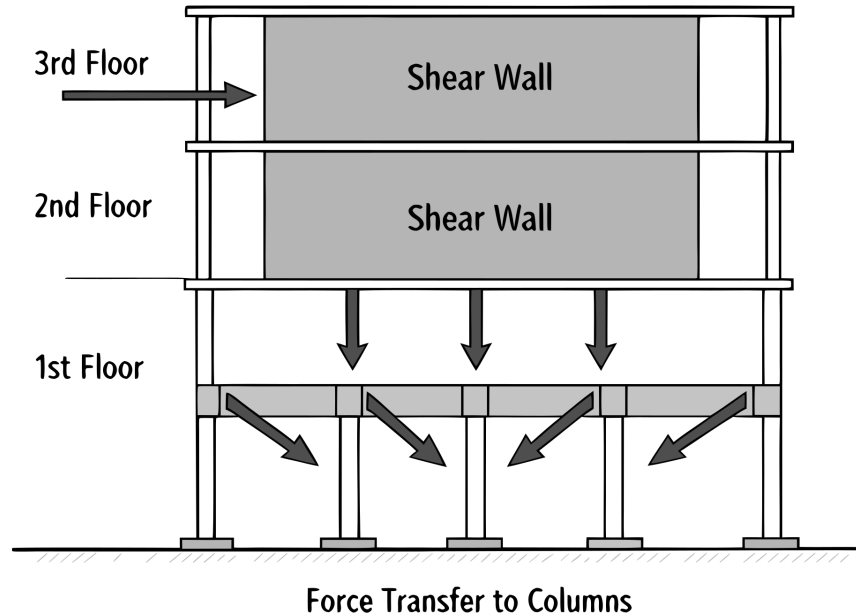

- A. When the columns below have a greater stiffness than the wall
- B. When the offset is greater than the length of the element
- C. When the offset is greater than the story height
- D. When the wall is thicker than the columns below

30. When calculating the seismic base shear using the Equivalent Lateral Force (ELF) procedure, what is the default Response Modification Coefficient (R) for an Ordinary Steel Moment Frame?

- A. 5.0
- B. 8.0
- C. 3.5
- D. 1.5

31. Which analysis procedure accounts for the timing of modal peaks using the Square Root of the Sum of the Squares (SRSS) or Complete Quadratic Combination (CQC)?

- A. Modal Response Spectrum Analysis
- B. Simplified Procedure
- C. Linear Static Analysis
- D. Equivalent Lateral Force Procedure

32. In the Equivalent Lateral Force Procedure, what does "W" represent in the base shear formula $V = C_s * W$?

- A. Wall Load
- B. Wind Load
- C. Effective Seismic Weight
- D. Working Stress

33. True or False: ASCE 7-16 requires specific seismic detailing for structures assigned to Seismic Design Category A.

- A. Only for structures over 5 stories
- B. Only for essential facilities
- C. True
- D. False

34. According to ASCE 7-16, when is the Dynamic Analysis (Modal Response Spectrum) procedure required instead of the Equivalent Lateral Force (ELF) procedure?

- A. Tall or highly irregular structures
- B. All structures in SDC A
- C. Any structure with a rigid diaphragm
- D. Simple 1-story buildings

Exam page: californiacerts.com/exams/ca-civil-seismic

Online practice: californiacerts.com/exams/ca-civil-seismic/practice

35. For concrete Special Moment Frames, what is the maximum allowed spacing of transverse reinforcement (hoops) within the plastic hinge region?
- 8 times the bar diameter
 - Smallest of $d/4$, 6 bar diameters, or a specified formula
 - Constant 12 inches
 - $d/2$ or 12 inches
36. In the vertical load path, what is the primary function of a collector (drag strut)?
- Transfer diaphragm forces to vertical resisting elements
 - Support vertical gravity loads only
 - Resist uplift from wind forces
 - Distribute live loads evenly across the floor
37. The redundancy factor (ρ) is used to account for the reliability of the lateral force-resisting system. What is the typical range of values for ρ ?
- 1.5 or 2.0
 - 1.2 to 1.5
 - 0.5 to 1.0
 - 1.0 or 1.3
38. Based on the provided detail of a Special Moment Frame (SMF) beam-column joint, what is the length of the critical plastic hinge zone where closely spaced transverse reinforcement (hoops) must be provided?

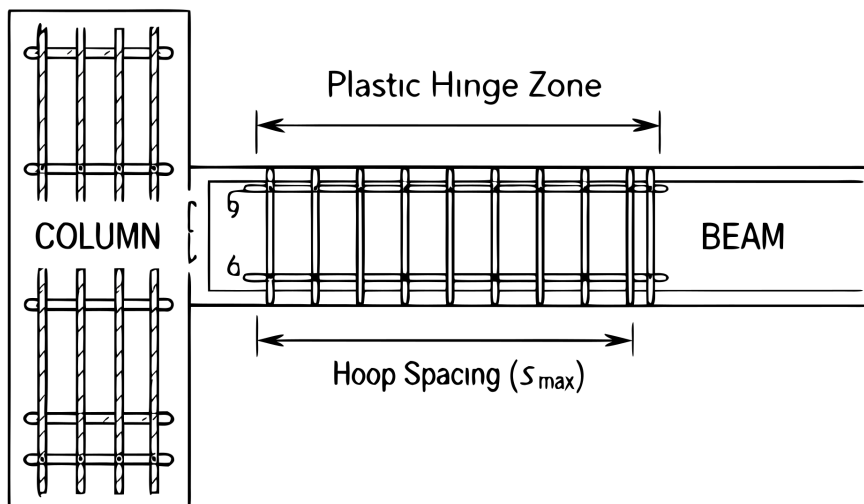

- 1.5 times the beam depth ($1.5h$)
 - 3 times the beam depth ($3h$)
 - 2 times the beam depth ($2h$)
 - The clear span of the beam divided by 4 ($L/4$)
39. What is the minimum specified concrete compressive strength (f'_c) for structures assigned to SDC D, E, or F?
- 4,000 psi
 - 5,000 psi
 - 2,500 psi
 - 3,000 psi
40. Which document is the primary reference for the seismic detailing of structural steel buildings in the United States?
- ACI 318
 - NDS
 - ASCE 41
 - AISC 341

41. What is the maximum allowable value for the stability coefficient (θ) in P-Delta analysis?
 A. 0.25
 B. 0.10
 C. 1.0
 D. 0.50
42. Based on the provided elevation diagram indicating $K_1 < 0.7 * K_2$, what type of structural irregularity is present according to ASCE 7-16 Table 12.3-2?

Soft Story Irregularity (Type 1a / 1b)

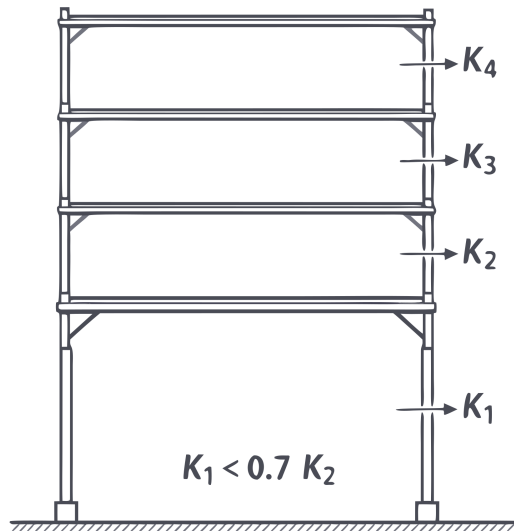

- A. Weak Story Irregularity
 B. In-Plane Discontinuity
 C. Soft Story Irregularity
 D. Vertical Geometric Irregularity
43. Which retrofit technique is most effective at reducing the seismic demand on a stiff, brittle structure?
 A. Installing viscous dampers
 B. Adding concrete shear walls
 C. Adding braced frames
 D. Base isolation
44. What is the required hook angle for a "Seismic Hook" used in the transverse reinforcement of a ductile concrete member?
 A. 180 degrees
 B. 135 degrees
 C. 90 degrees
 D. 45 degrees
45. For a structure with a fundamental period $T \geq 2.5$ seconds, what is the value of the exponent k used for the vertical distribution of seismic forces?
 A. 2.0
 B. 2.5
 C. 1.0
 D. 1.5
46. When calculating story drift, the displacements determined from an elastic analysis (δ_{xe}) must be multiplied by which factor?
 A. C_d / I_e
 B. 1.5
 C. R / I_e
 D. Ω_0

47. For the design of nonstructural components, the horizontal seismic force (F_p) is calculated using which ASCE 7-16 chapter?

- A. Chapter 12
- B. Chapter 15
- C. Chapter 11
- D. Chapter 13

48. True or False: ASCE 41-17 is the primary standard used for the seismic evaluation and retrofit of existing buildings.

- A. Only applies to new construction
- B. Only applies to bridges
- C. False
- D. True

49. What is the primary objective of seismic retrofitting an existing building to a "Life Safety" performance level?

- A. Ensure zero architectural damage
- B. Maintain full functionality
- C. Prevent total collapse
- D. Eliminate all seismic forces

50. According to ASCE 7-16 Section 12.10.1.1 and the provided diaphragm diagram, the seismic design force for diaphragms (F_{px}) shall NOT be less than which of the following limits?

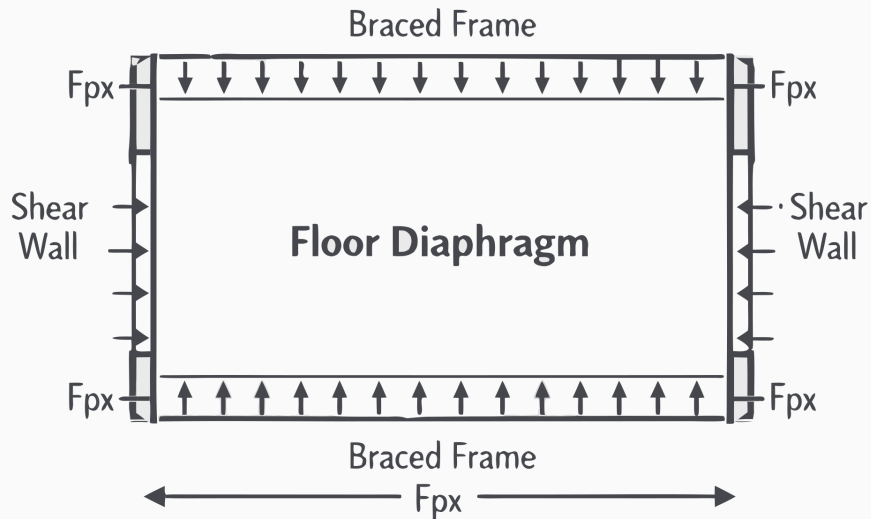

- A. $0.1 S_{ds} * I_e * w_{px}$
- B. $0.2 S_{ds} * I_e * w_{px}$
- C. $0.4 S_{ds} * I_e * w_{px}$
- D. $0.3 S_{ds} * I_e * w_{px}$

51. The diagram shows the first three vibration modes of a building. When performing a Modal Response Spectrum Analysis per ASCE 7-16 Section 12.9.1, the analysis must include a sufficient number of modes to obtain a combined modal mass participation of at least:

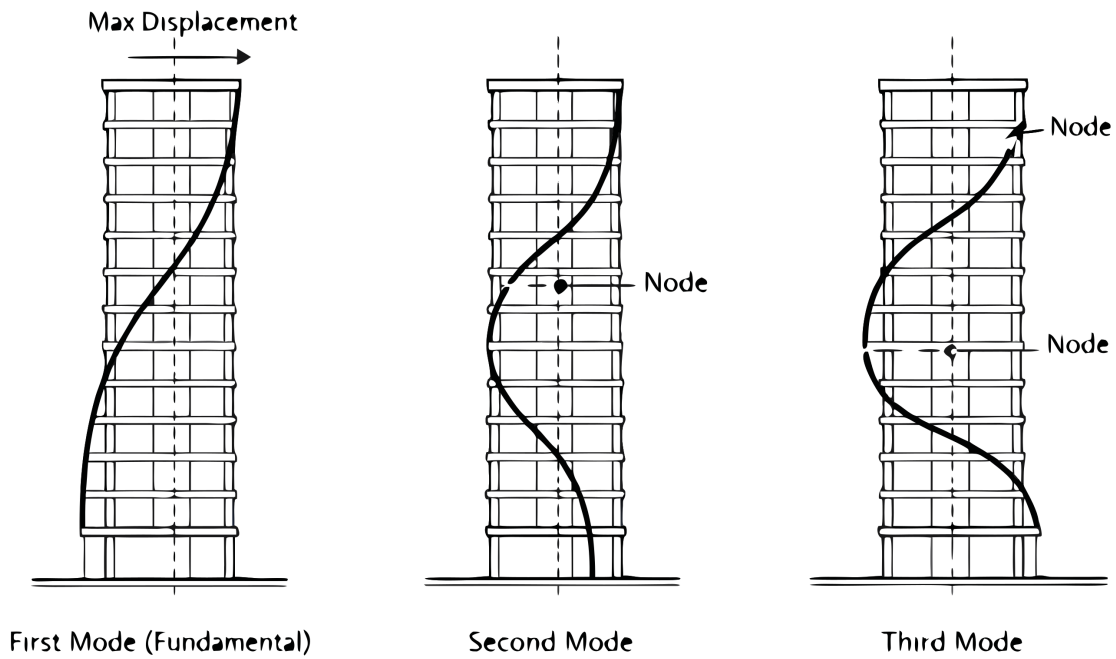

- A. 90 percent
- B. 100 percent
- C. 75 percent
- D. 80 percent

52. The detail drawing shows a post-installed mechanical expansion anchor. Which dimension correctly identifies the 'effective embedment depth' (h_{ef}) used for calculating concrete breakout strength in tension?

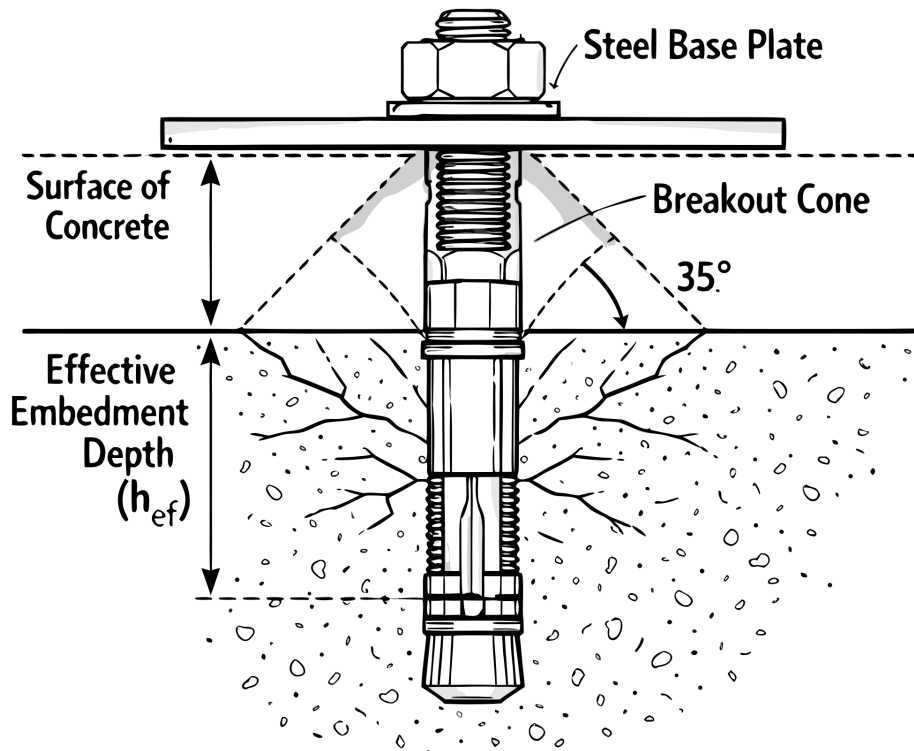

- A. The depth from the concrete surface to the deepest point of load transfer (the expansion mechanism)
- B. The thickness of the base plate plus the washer and nut
- C. The total overall length of the steel anchor bolt
- D. The distance from the concrete surface to the bottom of the drilled hole

53. In masonry shear walls, what is the purpose of "Grouting" the cells containing reinforcement?

- A. To bond the reinforcement to the masonry units
- B. To prevent moisture intrusion
- C. To provide a smooth finish for painting
- D. To reduce the weight of the wall

54. For wood-frame shear walls, which component is critical for transferring uplift forces between floors?

- A. Hold-downs (tie-downs)
- B. Anchor bolts only
- C. Shear transfer plates
- D. Drag struts

55. Based on the provided plan view of a roof diaphragm bending under a lateral load, ASCE 7-16 classifies a diaphragm as "Flexible" when its maximum lateral deflection (Δ_D) exceeds what value relative to the average drift of the vertical elements?

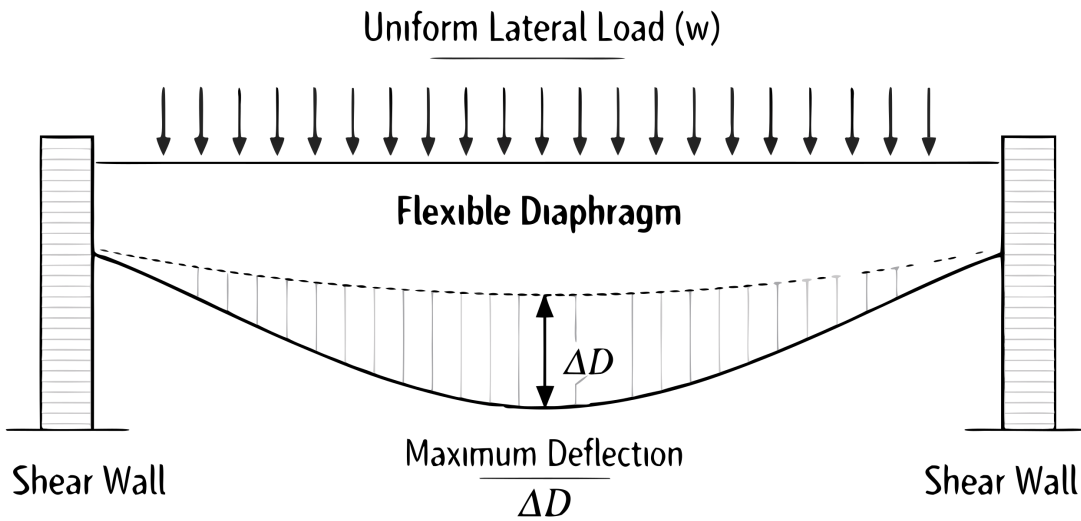

- A. More than 1.5 times the average drift
- B. More than 3 times the average drift
- C. More than 0.5 times the average drift
- D. More than 2 times the average drift